



**SUPERFREEZE**



LIQUID LEVEL INDICATOR  
LIQUID LEVEL INDICATOR

TYPE : SLLI

## REFRIGERANTS

Suitable for all common Refrigerants including R-717 (Ammonia), R-134a, R-22, neutral, gaseous and liquid media

## INTRODUCTION

The unbreakable Reflex Glass liquid level gauge is designed for safe & positive visual indication of liquid level in vessels under high pressure & temperature conditions. The liquid chamber is one piece metal body covered by glass. The light striking the glass in the liquid portion is absorbed by the liquid where as the light striking the glass in the vapor portion is reflected making the liquid appear as black.

## APPLICATION

It is suitable for monitoring liquid refrigerant & oil level for vessels as follows.

1. Receiver
2. Accumulator
3. Oil transfer drums
4. Low temp. Accumulator
5. Low temp. Oil transfer drums etc.

## MATERIAL SPECIFICATION

Front frame	: Steel ASTM A-108
Back frame	: Steel ASTM A-108
Sight glass	: Clear Boro-silicate tempered glass
Gasket	: Non Asbestos
Stop valve	: Forged steel ASTM A-350
Safe working pressure	: 365psig (25 bar)
Operating temperature	: -46°C to 116°C (-50F to 240F)

## FEATURES

1. Tempered borosilicate glass resistant to chemical, thermal and mechanical shocks.
2. Large chamber for boiling, flashing or surging liquids
3. Safety ball gauge valve provided.

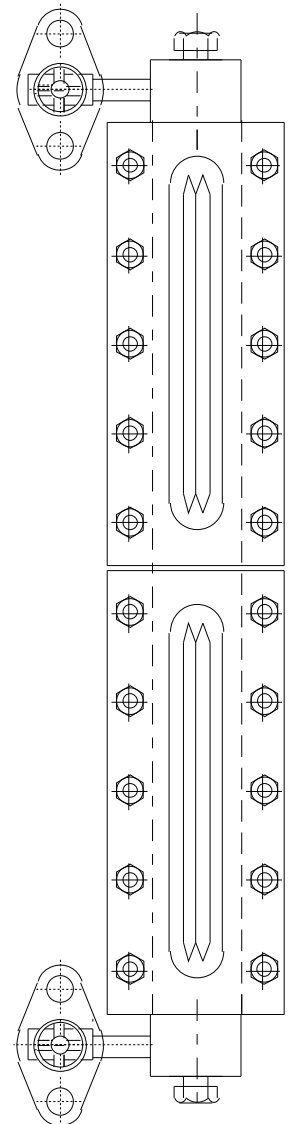

## INSTALLATION DIMENSION

SIZE		A	B	C	D
6"	150mm	240mm	75mm	178mm	228mm
12"	300mm	393mm	75mm	178mm	381mm
18"	457mm	545mm	75mm	178mm	533mm
24"	610mm	698mm	75mm	178mm	686mm
30"	762mm	850mm	75mm	178mm	838mm
36"	914mm	1002mm	75mm	178mm	990mm
42"	1067mm	1155mm	75mm <td 178mm	1143mm	
48"	1220mm	1307mm	75mm	178mm	1295mm
60"	1524mm	1612mm	75mm	178mm	1600mm

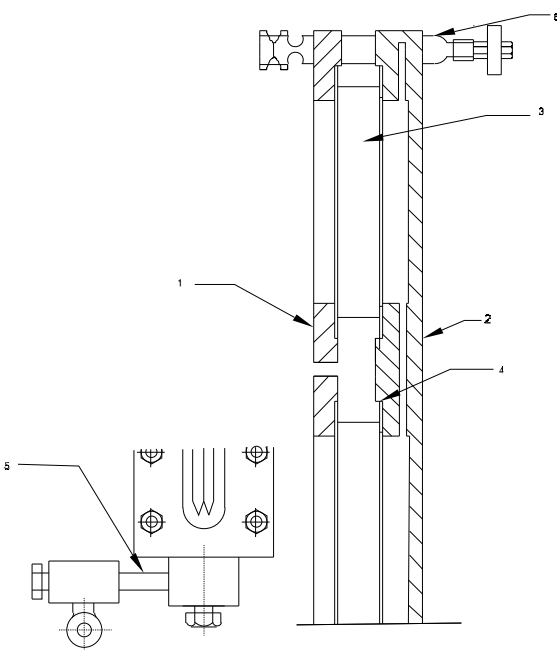
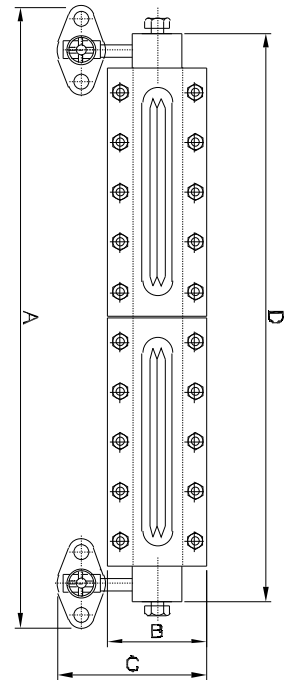

## PART LIST

NO	Part	Qty	Part No.
1	Front frame	2	85162600
2	Back frame	1	85162500
3	Sight glass	2	85162103
4	Gasket	4	85161100
5	Welding nipple	2	85162200
6	Stop valve	2	25010000



**SUPERFREEZE**

# LIQUID LEVEL INDICATOR

## ORDERING INFORMATION

Size	Cat. No.
6" (150mm)	SLLI 150S
12" (300mm)	SLLI 300S
18" (457mm)	SLLI 457S
24" (610mm)	SLLI 610S
30" (762mm)	SLLI 762S
36" (914mm)	SLLI 914S
42" (1067mm)	SLLI 1067S
48" (1220mm)	SLLI 1220S
60" (1524mm}	SLLI 1524S

### EXAMPLE:

#### SUPERFREEZE LEVEL INDICATOR SLLI-150S

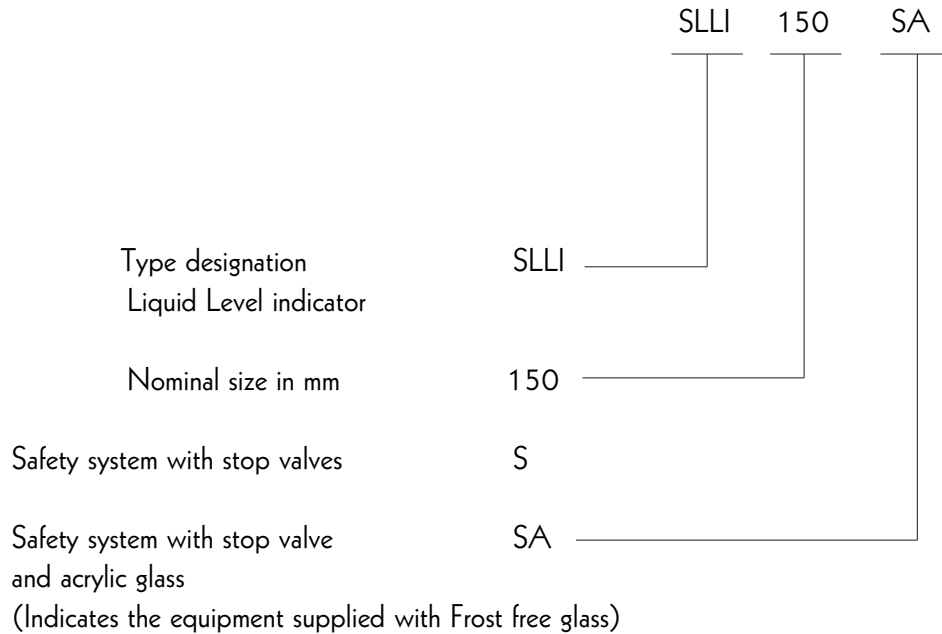

**SUPERFREEZE INDIA LIMITED**

122, Qutab Plaza DLF Phase-1  
Gurgaon-122002 (Haryana), India.

Tel: +91-124-4301636, +919810048749

Fax: +91-1276-241549

Email: sales@superfreeze.com

Website: www.superfreeze.com