



SUPERFREEZE



FLOAT SWITCH
FLOAT SWITCH



SUPERFREEZE

FLOAT SWITCH 38SFS

TYPE : 38SFS

REFRIGERANTS

suitable for all common non-flammable refrigerants including R-717 (Ammonia) and non-corrosive gases and liquid.

FEATURES

- Based on superfreeze float type 38SLC.
- DIN,ANSI and FPT/NPT flanges.
- Switch assembly can be rotated at 360° and placed in any position for easy installation.
- Adjustable liquid level differential switch point.
- Electro magnetic micro switch, mechanically activated.
- The complete switch box can easily be replaced with out any interference with refrigeration system.
- Switch box supplied with DIN plug for easy of installation and service.
- Counter flanges are included

INTRODUCTION

Float switch type 38SFS is an electro-mechanical float switch designed to provide a reliable, electro-mechanical response to liquid level changes. The simple and rugged design ensures long service life performance and reliable operation for many applications such as,

1. Level control by liquid fill solenoid Valve.
2. High level cut-out or alarm.
3. Low level cut-out or alarm.
4. Low level pump cut-out.
5. Level control by liquid exit solenoid Valve.
6. Level indication by pilot light.
7. Transfer drum operation.

The design incorporates a mechanical float which will operate in the refrigerant, when the set level is reached an electrical volt free micro switch will be activated.

The micro switch is located in the switch box which has a clear front cover and allows viewing of the switch positions. The micro-switch is fully isolated from the refrigeration system and operates by means of magnet.



SUPERFREEZE

FLOAT SWITCH 38SFS

TECHNICAL SPECIFICATION

1. Maximum Operating Pressure : 28 bar (406 psig)
2. Operating temperature range : -50°C to +65°C
3. Change over Micro (SPDT) Switch : AC : 250V/ 10A
DC : 30V / 5A
4. Function : Normally Open (NO) & Normally Closed (NC)
5. DIN Plug : DIN 43650 Connection PG11, 8-10mm.
Screw terminal 1.5 to 2mm (16AWG) 3+PE
6. Liquid level differential : Variable between 12.5 to 50mm (1/2" to 2") in 12.5mm
(1/2") Increments.
7. Enclosure : IP 65
8. Weight : Approx. 10kg (including flanges)

APPLICATIONS

For the control and detection of liquid levels in:-

- Liquid over-feed accumulators.
- Flooded surge drums.
- Flooded shell and tube chillers.
- High and low pressure receivers.
- Inter coolers.
- Use as low/high level safety switch to protect circulating pumps/compressors.



SUPERFREEZE

FLOAT SWITCH 38SFS

DIMENSIONS

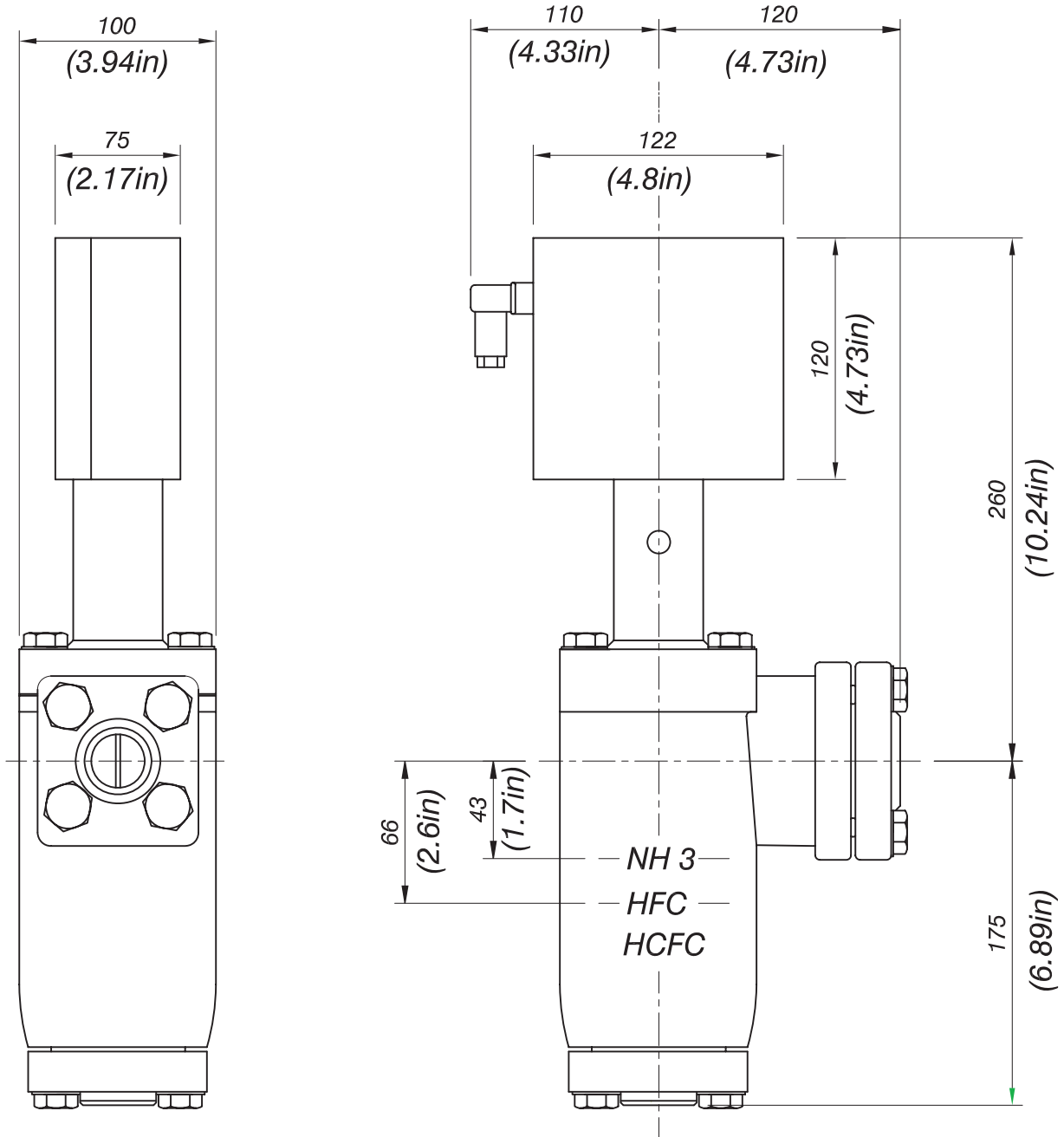

FLOAT SWITCH (38SFS) ASSEMBLY



SUPERFREEZE

FLOAT SWITCH 38SFS

PART LIST

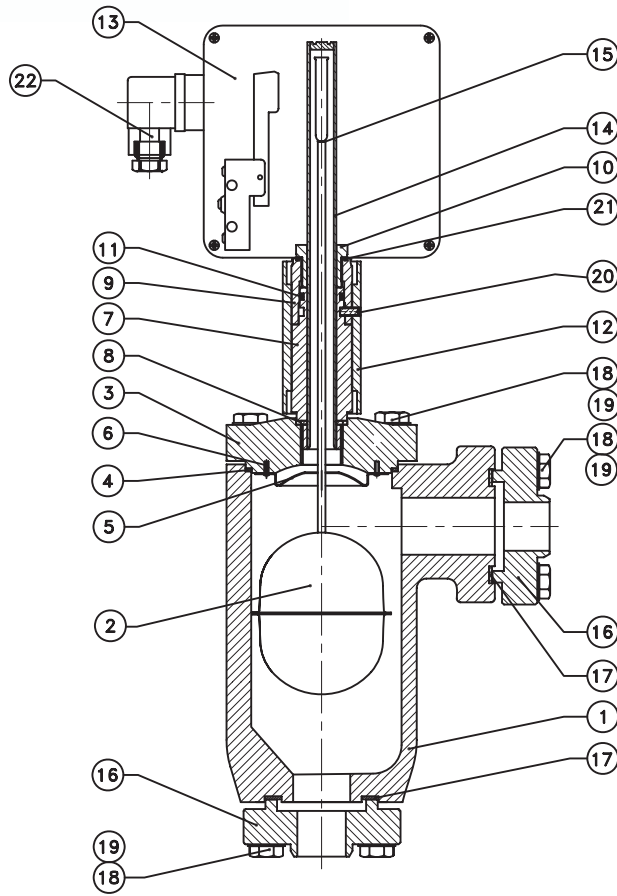

FLOAT SWITCH (38SFS) ASSEMBLY

22	DIN PLUG	900337R3	01
21	O-RING	9003082327R1	01
20	GRUB SCREW M4X6	GM4L6S9	01
19	SPRING WASHER B-12.2	SWB12S9	12
18	HEX. BOLT M12X1.75, L=40	HSM12L40S9	12
17	GASKET	9003114260R2	02
16	FLANGE	900318S7	02
15	LOCKING RING	CB3S12	02
14	PRESSURE TUBE	900336S11	01
13	SWITCH BOX	900341R3	01
12	CAP	900340R3	01
11	O-RING	9003082024R1	01
10	GLAND NUT	900339NF4	01
9	GLAND	900338NF4	01
8	GASKET	9003112227R2	01
7	ENCLOSING TUBE ASSEMBLY	900322S11	01
6	RIVET (SNAP HEAD)	RD2L5S9	04
5	DISH	900333S11	01
4	GASKET	9003117480R2	01
3	BONNET	900302C2	01
2	FLOAT ASSEMBLY	900331S11	01
1	BODY	900301C2	01
ITEM NO.	DESCRIPTION	PART NO	QTY.



SUPERFREEZE

FLOAT SWITCH 38SFS

INSTALLATION

1. Float switch 38SFS must always be installed in a vertical position (fig. 1)
2. Float switch 38SFS is supplied complete with flanges, fasteners and gasket (fig. 2, pos. 16,17,18&19)
The external surfaces of the flanges must be prevented against corrosion with a suitable protective coat after installation.
3. To avoid an oil seal forming which would affect the movement of the internal float the bottom connecting pipe must have an incline towards the liquid separator (marked in red colour in (fig.1)
4. Shut –off valves should be mounted as close as possible to the float for service (fig. 1 & fig. 3)
5. The switch point is relative to the actual liquid level marking on the 38SFS body see (fig. 5)
 - The upper switch point is actually (D : 2) higher than the actual liquid level marking.
 - The lower Switch point is actually (D :2) lower than the actual liquid level marking, where D = DifferentialAdjusting the liquid level differential switch point (see fig. 7). The float comes factory set with a
 - Differential setting of 50mm (2") with the lower locking ring © in position b. to achieve smaller differential settings reposition the lower locking ring © at b1 = 37.5mm (1½") (b2=25mm, (1") b3 =12.5mm (1/2")) the upper locking ring Ⓓ in position a should not be adjusted or repositioned.
6. Important: The adjustment must be made before 38SFS is installed in the refrigeration system. Use two thumbs for repositioning the locking rings. Do not use any tools.
7. Remove the 38SFS Switch box (fig.2, pos. 13).
 - Unfasten the M4 x 8 (fig. 2. pos. 20) Grub screw with an Allen key.
 - Remove the switch box by slowly easing upwards.
8. Remove the 38SFS Bonnet or Top cover (fig. 2 pos.3)
 - Unfasten the 4 x M12 x 40 Hex bolt with Washer (fig. 2, pos 18&19)
 - Remove the complete Bonnet or Top cover including installed pressure tube (fig. 2, pos. 14)
9. Remove the complete float assembly (fig.2 , pos 2) and (fig.3, pos. 2) from the 38SFS body (fig.2, pos.1)
 - Reposition the lower locking ring at the required differential setting (see fig.6 and fig.7)

RE-ASSEMBLY

10. Refit the float assembly back into the 38SFS body (fig.2, pos.1)
11. Reinstall the complete Bonnet or top cover (fig.2,pos. 3) and fasten the 4 x M12 x40 Bolts with Washer (fig.2, pos. 18&19) ensure the max. tightening Torque:74Nm.(100 ft.lb)
12. Reinstall the switch box (fig.2, pos.13) by slowly forcing it down over the pressure tube (fig.2, pos.14)
13. Position the Switch box (fig.2,pos,13) as required and fasten the M4 x 8 grub screw (fig.2,pos.20) with an allen key

ELECTRICAL INSTALLATION

14. Electric installation make electrical connection to DIN plug using cable with maximum 4 cores and wire in accordance with wiring diagram (fig.6)
 - (a) Common
 - (b) Normally Closed
 - (c) Normally Open
 - (d) Earth terminal



SUPERFREEZE

FLOAT SWITCH 38SFS

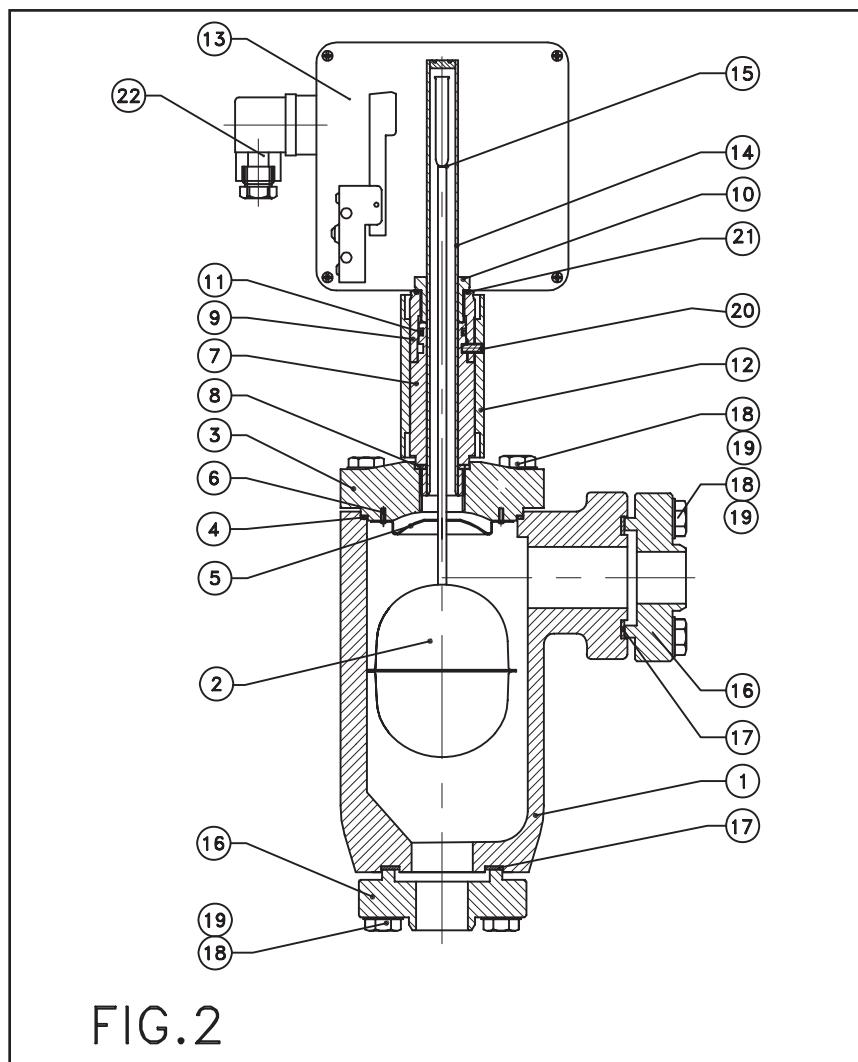
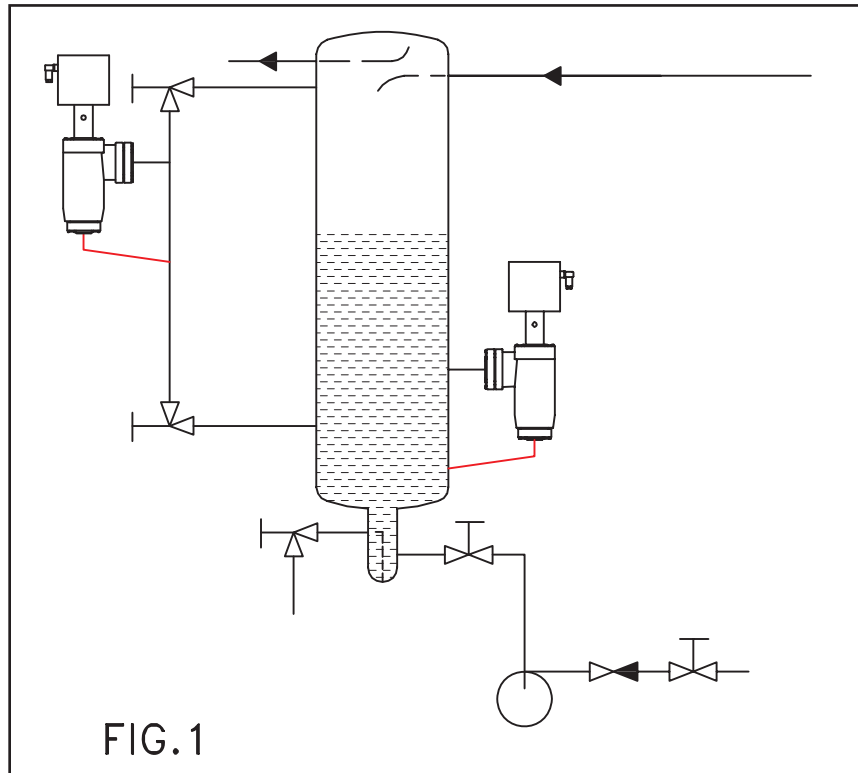



SUPERFREEZE

FLOAT SWITCH 38SFS

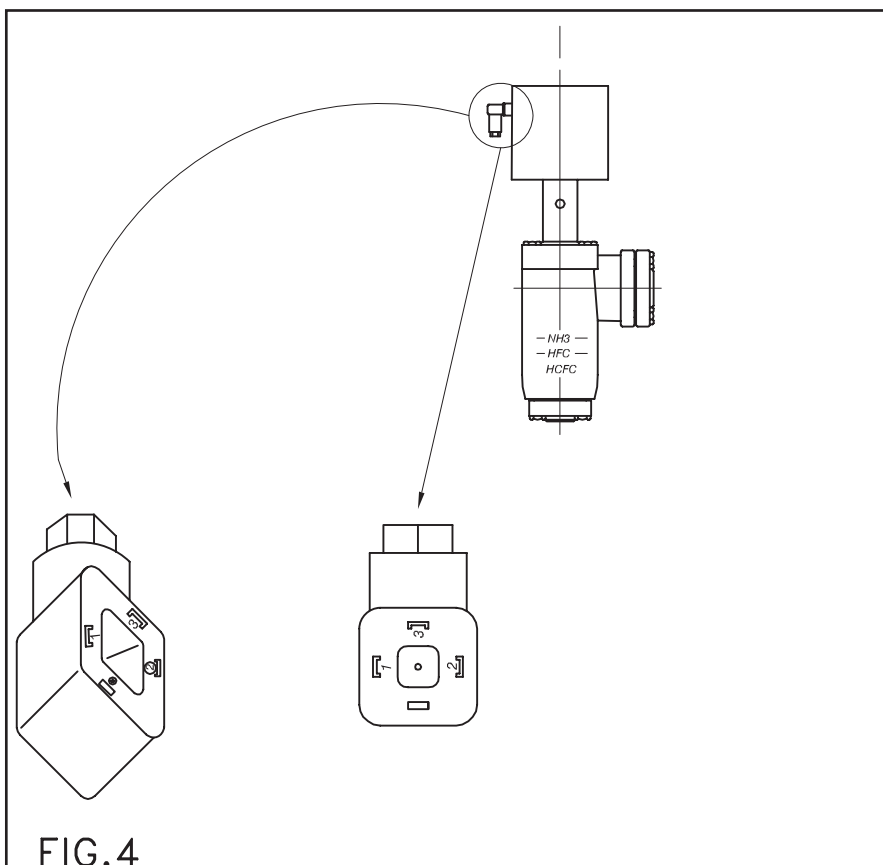
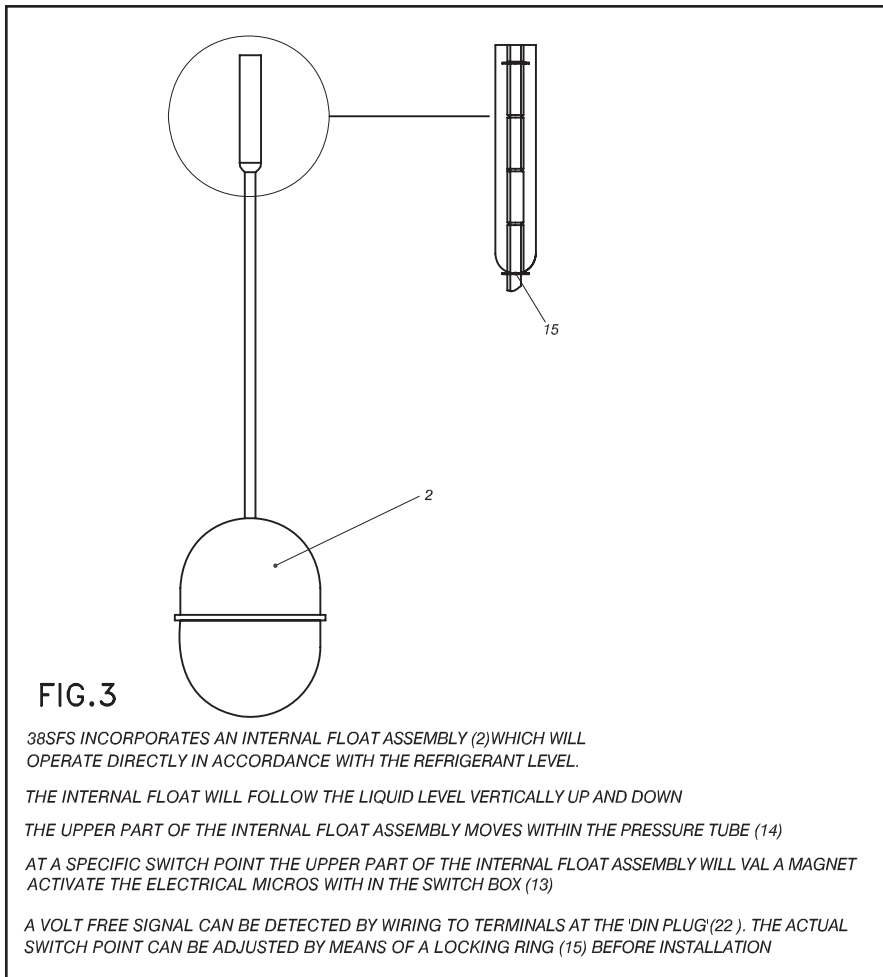



SUPERFREEZE

FLOAT SWITCH 38SFS

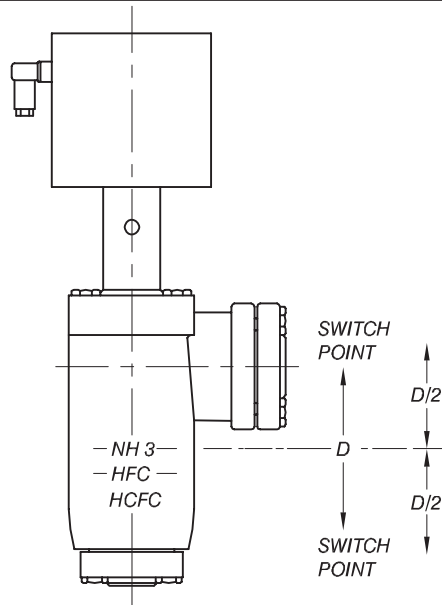

FIG.5

THE SWITCH POINT IS RELATIVE TO THE ACTUAL LIQUID LEVEL MARKING ON THE 38SFS BODY (SEE FIG. 5)

THE UPPER SWITCH POINT IS ACTUAL (D:2) HIGHER THAN THE ACTUAL LIQUID LEVEL MARKING.

THE LOWER SWITCH POINT IS ACTUAL (D : 2) LOWER THAN THE ACTUAL LIQUID LEVEL MARKING WHERE "D" = DIFFERENTIAL.

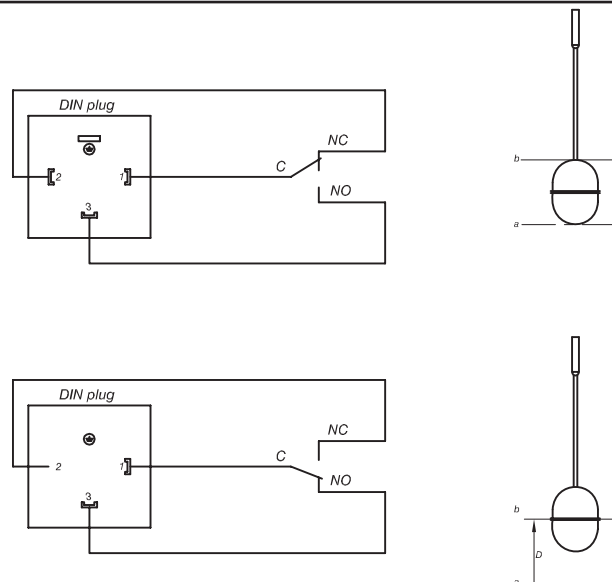

FIG.6

ELECTRICAL INSTALLATION
MAKE ELECTRICAL CONNECTION TO 'DIN PLUG' USING CABLE WITH MAXIMUM 4 CORES AND WIRE IN ACCORDANCE WITH WIRING DIAGRAM. (FIG. 6)

- 1. COMMON
- 2. NORMALLY CLOSED
- 3. NORMALLY OPEN
- 4. EARTH TERMINAL

DIFFERENTIAL (D) = VARIABLE BETWEEN 12.5mm (1/2") to 50mm (2") IN 12.5mm (1/2") INCREMENTS.



SUPERFREEZE

FLOAT SWITCH 38SFS

